

HEADER SYSTEMS

TOUGH STUFF® Header Systems are the best in the industry for the most important reasons:

Quality Materials

TOUGH STUFF Header Systems are manufactured of durable Schedule 80 fittings and pipe, and end plugs are machined of solid bar or plate stock. All raw materials meet strict quality control procedures when entering the plant and again when leaving as a finished product.

Progressive Engineering

MATTSON/WITT always seeks to improve TOUGH STUFF Header Systems with creativity. For example, instead of simply tapping into the side wall of the header pipe, Schedule 80 threaded couplings are welded to allow a more integral thread engagement of the laterals. This method also places less stress on the side wall of the header pipe.

Computer Automated Design

After receipt of an order, MATTSON/WITT's engineers will create a print of your complete header system and fax it to you for approval prior to manufacturing.

Pricing

A TOUGH STUFF Header System can be manufactured and shipped for a fraction of the cost of a stainless steel header system.

Delivery

Lead time is approximately 4 weeks, dependent on design approval.

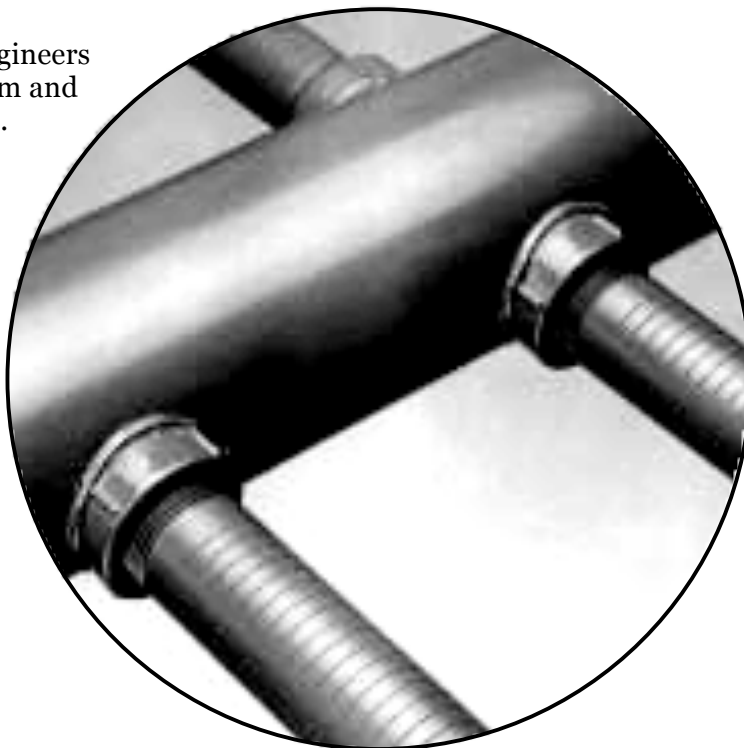

TECHNICAL SPECIFICATIONS

Maximum recommended operating temperature	
For PVC	140°F (60°C)
For CPVC	160°F (71°C)
For polypropylene	180°F (82°C)
For Teflon	200+°F (93+°C)
For PVDF	200+°F (93+°C)
Maximum recommended operating pressure	150 PSI
ΔP @ 5 ft./sec. velocity	≤ 3 PSI



HEADER SYSTEM DESIGN

Questions we ask when quoting or designing a TOUGH STUFF® Header System:

1. What are the tank dimensions and is there a print of the tank available?
2. What type of connections will be used to connect the distribution system to the tank? Are they threaded (NPT or other)? Are they flanged (ANSI or other)? Are the connections internal or external? NOTE: If the distribution system is to be connected to the tank on the outside of the tank, the distributor pipe will be one size smaller than the tank connection.
3. Where will the inlet and outlet connections be located?
4. What size are the connections in the tank?
5. What is the flow rate required in service and in backwash?
6. What slot size will be required? If not known, what type of media will be used in the tank?
7. What materials will be required? If not known, we will ask more about the application.
8. What type of inlet distributor is required (open ended top header, diffuser with holes or slots, mirrored image of bottom header)?

Sizing the system

The size of the system will be dictated by the maximum flow of water required to flow through the system. MATTSON/WITT distribution systems will be sized so that the velocity doesn't exceed 5 ft./second as recommended by our plastic piping supplier.

What size is the header pipe?

Flow	Pipe Size
0-45 GPM.....	2"
45-100 GPM.....	3"
100-175 GMP	4"
175-400 GPM	6"
400-700 GPM	8"
700-1100 GPM	10"
1100-16 GPM.....	12"

What size are the laterals?

Header Size	Lateral Size
2".....	0.75"
3".....	1"
4".....	1.25"
6".....	1.50"
8".....	2"
10".....	2.50"
12".....	3"

What is the lateral spacing?

Header Size	Spacing
2".....	4.20"
3".....	5.26"
4".....	6.64"
6".....	7.70"
8".....	9.50"
10".....	11.50"
12".....	14"

How many laterals will there be?

FORMULA: Tank diameter (in inches) divided by the lateral spacing equals the number of laterals per side. Reduce this number to the next lower odd integer and multiply by 2. The result will be the total number of laterals for the header system.

